

A300 ÇEKİRDEK HAZNESİ

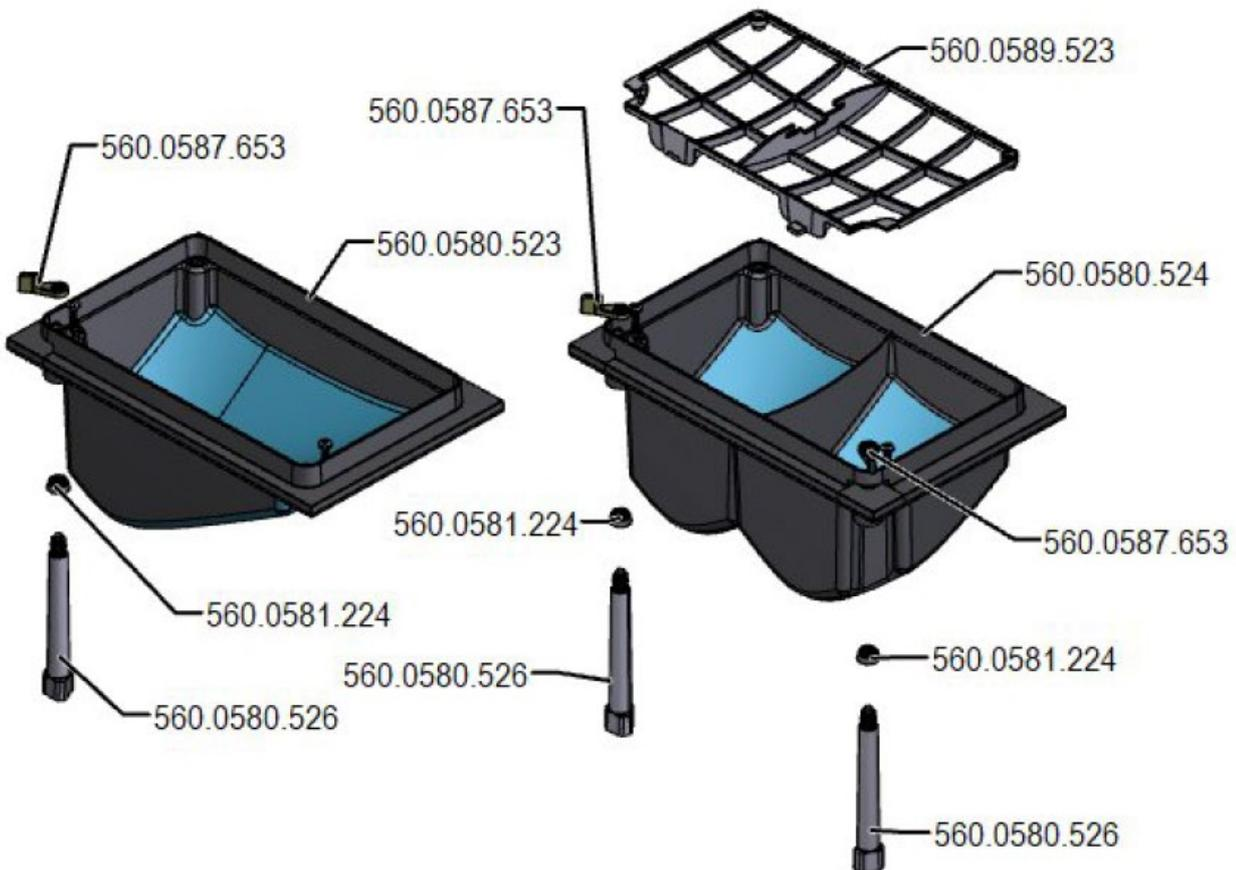
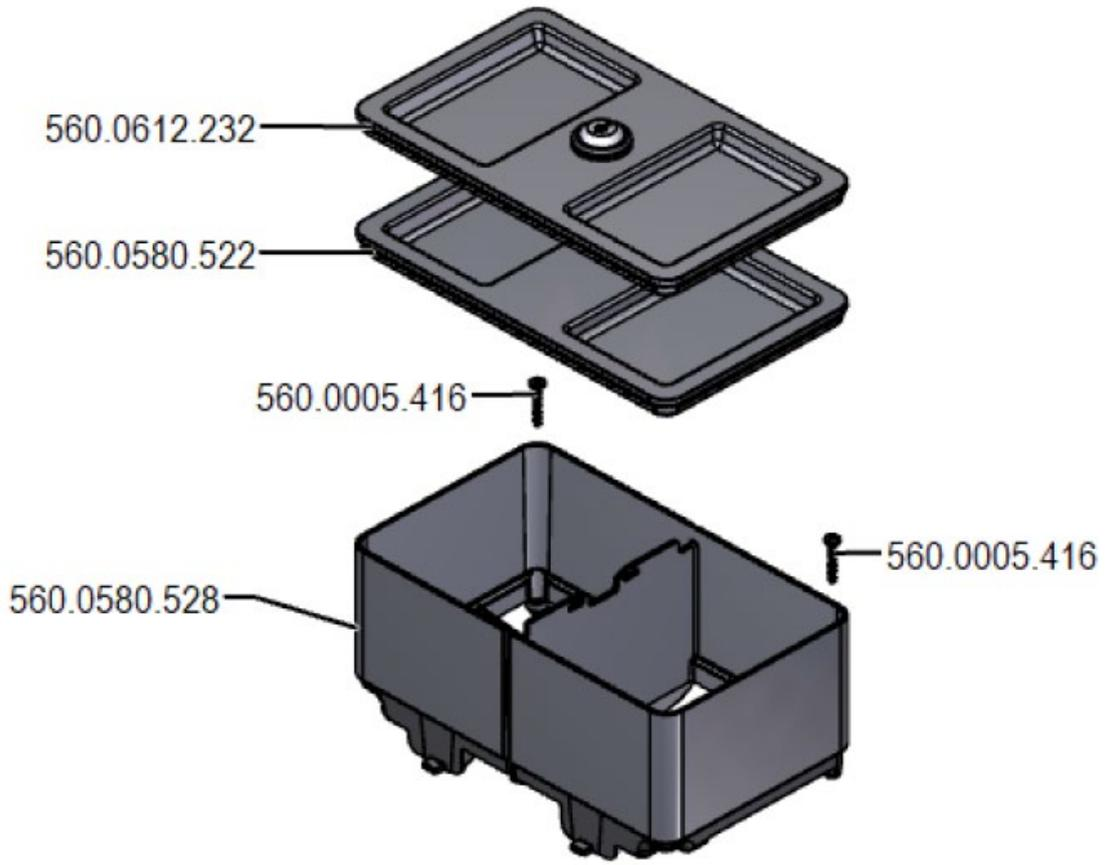

Pan head PT screw, K30x20	
Pos. CSS:	5537
Art. No. SAP:	560.0005.416
<hr/>	
Bean hopper lid	
Pos. CSS:	560.0580.522
Art. No. SAP:	560.0580.522
<hr/>	
Bean hopper single	
Pos. CSS:	560.0580.523
Art. No. SAP:	560.0580.523
<hr/>	
Bean hopper double	
Pos. CSS:	560.0580.524
Art. No. SAP:	560.0580.524
<hr/>	
Grinder adjusting axle	
Pos. CSS:	560.0580.526
Art. No. SAP:	560.0580.526
<hr/>	

Bean hopper extension	
Pos. CSS:	560.0580.528
Art. No. SAP:	560.0580.528
<hr/>	
Guide	
Pos. CSS:	560.0581.224
Art. No. SAP:	560.0581.224
<hr/>	
Grinder adjusting lever	
Pos. CSS:	560.0587.653
Art. No. SAP:	560.0587.653
<hr/>	
Bean hopper finger guard	
Pos. CSS:	560.0589.523
Art. No. SAP:	560.0589.523
<hr/>	
Bean hopper lid lockable assembled	
Pos. CSS:	560.0612.232
Art. No. SAP:	560.0612.232
<hr/>	

A300 DEĞİRMEN

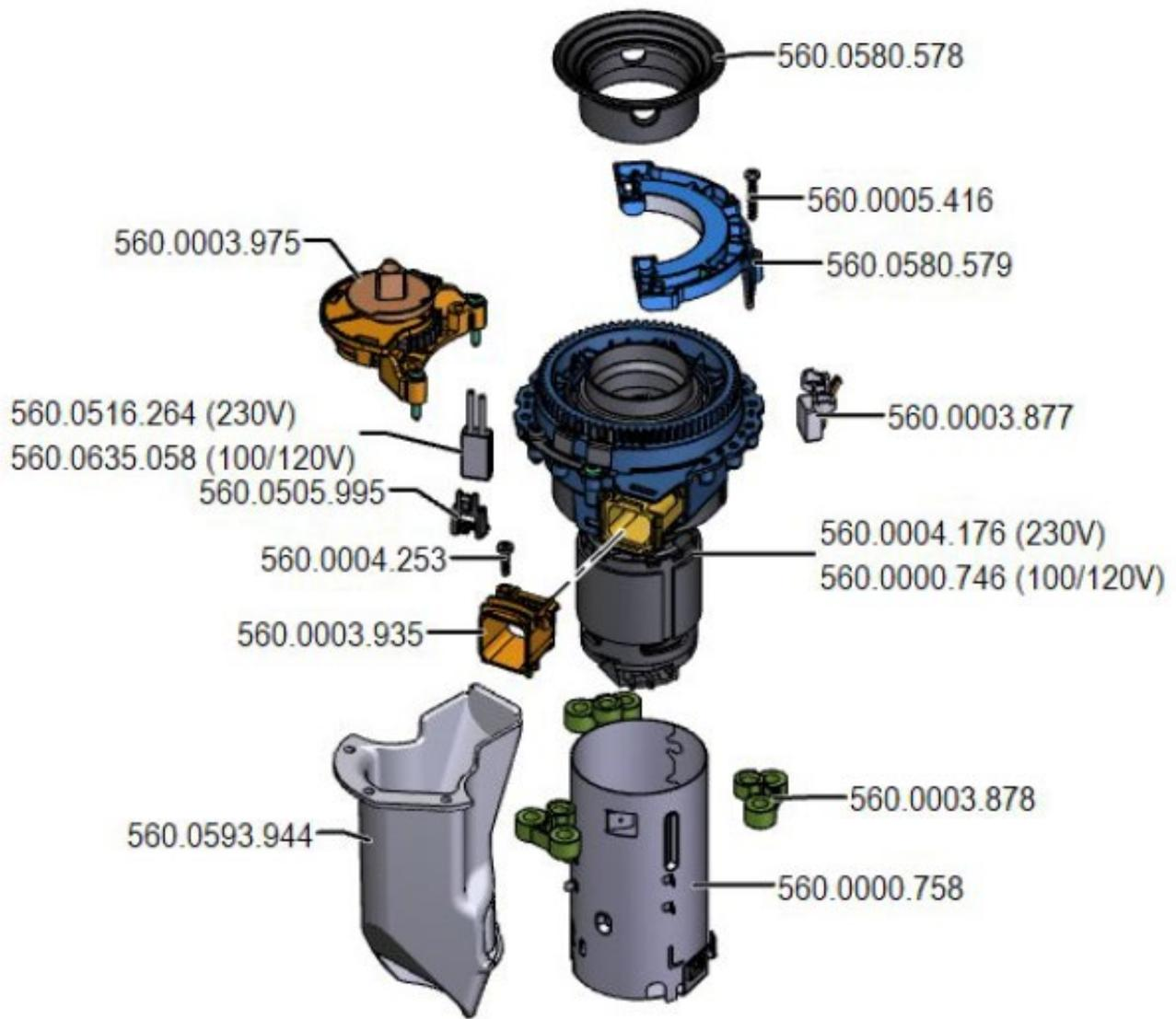

IR Lichtschanke
IR light barrier
IR barrière photoélectrique



Grinding unit 647 120 V complete V2	
Pos. CSS:	12584
Art. No. SAP:	560.0000.746
Cover plate 651 for grinder	
Pos. CSS:	12596
Art. No. SAP:	560.0000.758
Speed sensor	
Pos. CSS:	8483
Art. No. SAP:	560.0003.877
Vibration damper for grinder	
Pos. CSS:	8484
Art. No. SAP:	560.0003.878
Powder chute left-hand	
Pos. CSS:	8486
Art. No. SAP:	560.0003.935
Grinder adjustment mechanism	
Pos. CSS:	8819
Art. No. SAP:	560.0003.975
Grinder	
Pos. CSS:	80003
Art. No. SAP:	560.0004.176
Pan head PT screw, K30x12	
Pos. CSS:	37
Art. No. SAP:	560.0004.253

Pan head PT screw, K30x20	
Pos. CSS:	5537
Art. No. SAP:	560.0005.416
Support	
Pos. CSS:	560.0505.995
Art. No. SAP:	560.0505.995
Thermal fuse cable for grinder	
Pos. CSS:	1S000556
Art. No. SAP:	560.0516.264
Sleeve	
Pos. CSS:	560.0580.578
Art. No. SAP:	560.0580.578
Mounting bracket for IR sensor	
Pos. CSS:	560.0580.579
Art. No. SAP:	560.0580.579
Cable IR light barrier	
Pos. CSS:	560.0593.532
Art. No. SAP:	560.0593.532
Ground coffee chute FCS4070	
Pos. CSS:	560.0593.944
Art. No. SAP:	560.0593.944
Cable grinder thermal fuse	
Pos. CSS:	560.0635.058
Art. No. SAP:	560.0635.058

A300 DEMLEME ÜNİTESİ

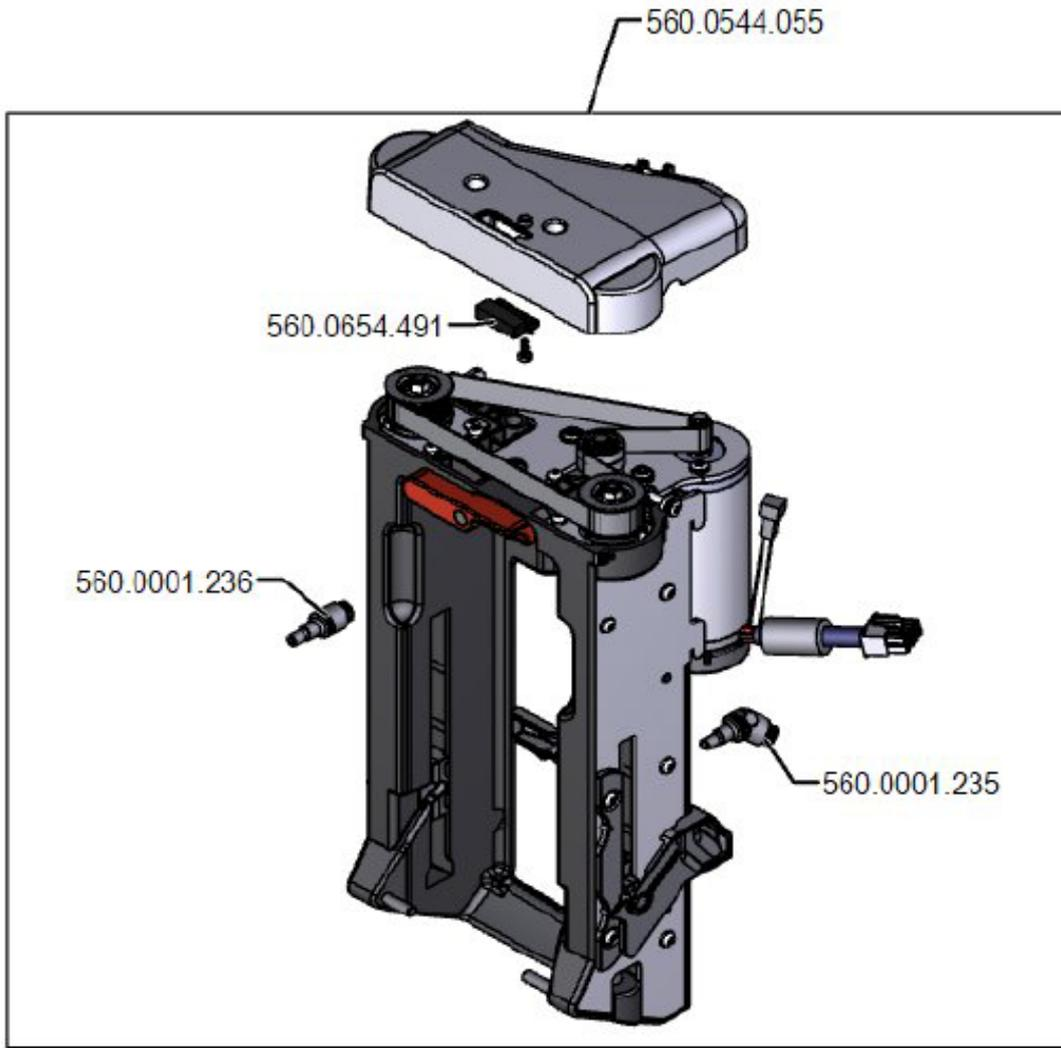

43E

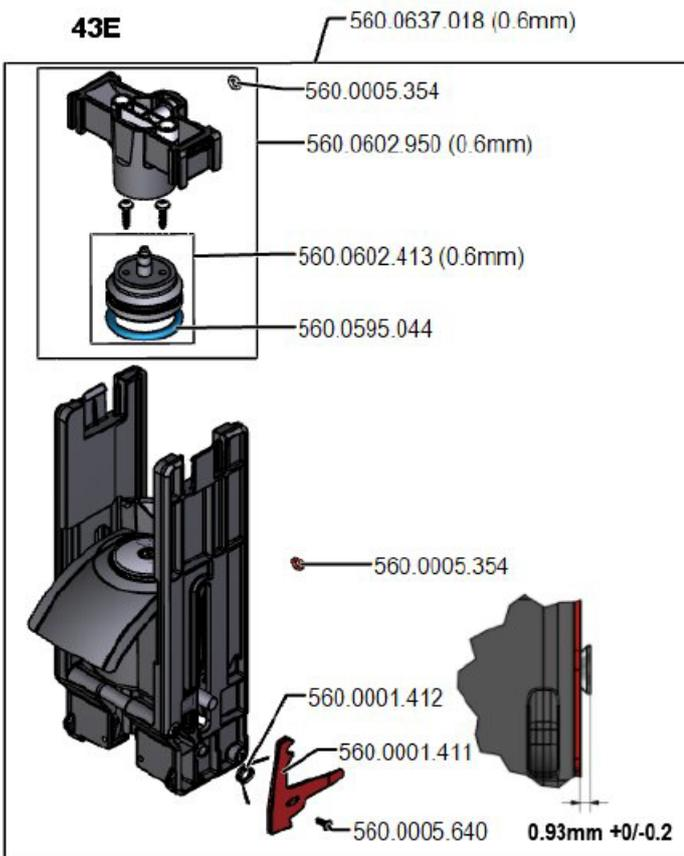

50E

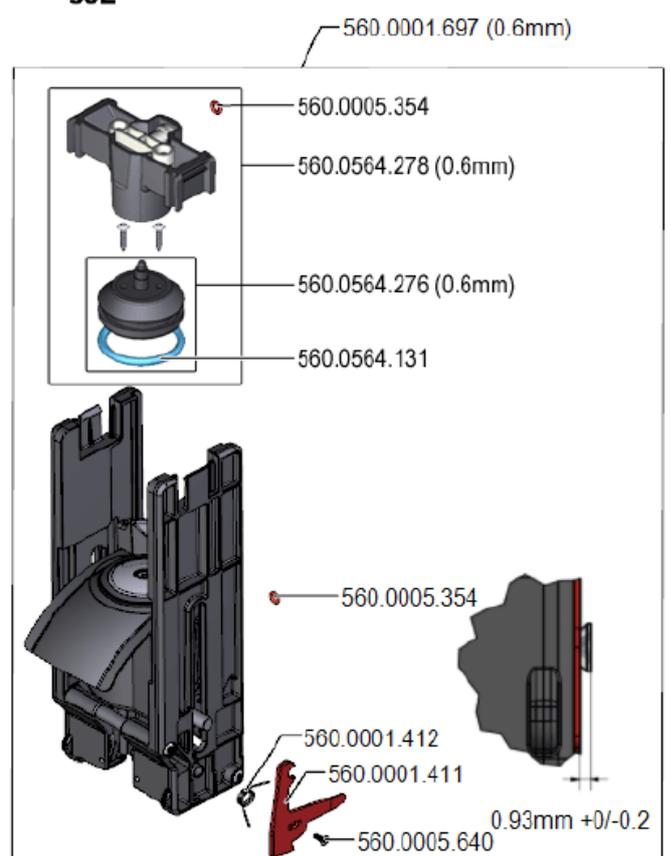

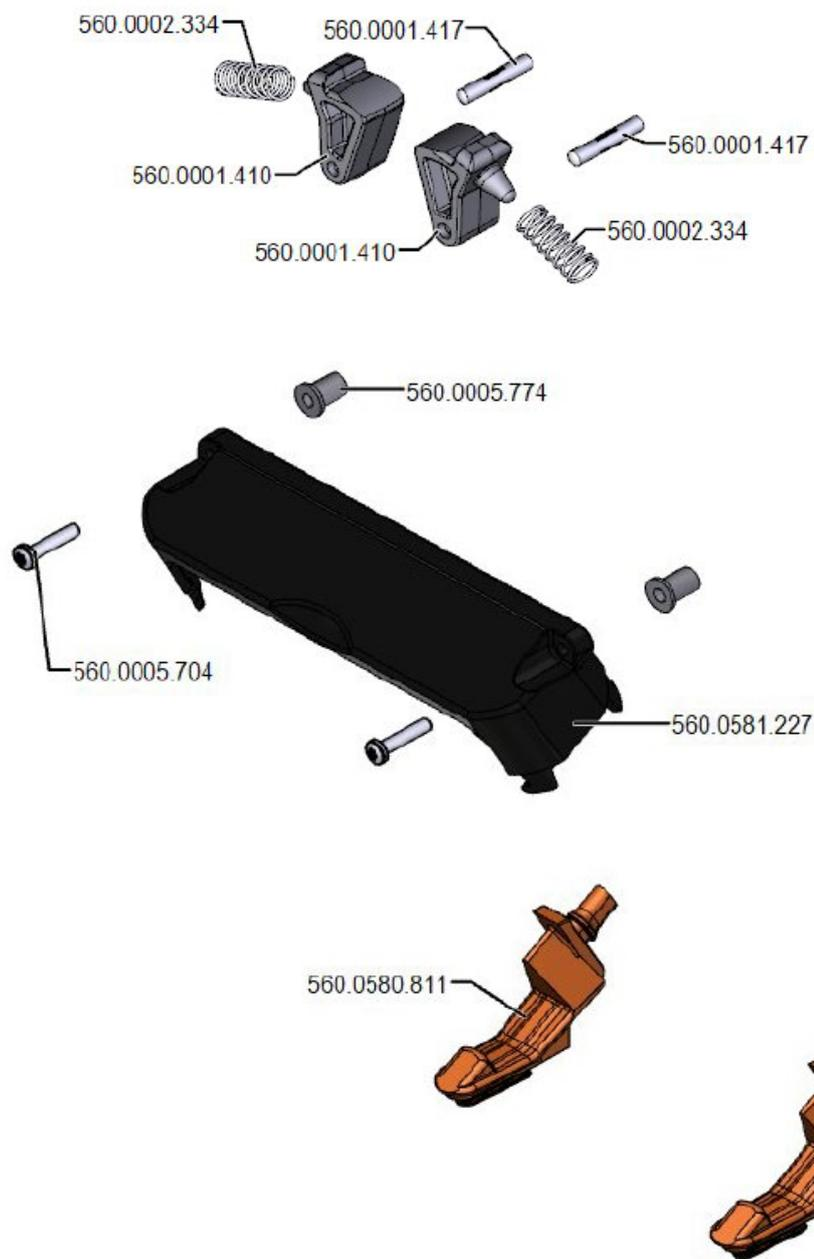

Push-fit elbow union Ø4 PPSU

Pos. CSS: 14213
 Art. No. SAP: 560.0001.235

Push-fit union Ø4 PPSU

Pos. CSS: 14214
 Art. No. SAP: 560.0001.236

Latch for brewing module

Pos. CSS: 560.0001.410
 Art. No. SAP: 560.0001.410

Brewing chamber locking mechanism

Pos. CSS: 560.0001.411
 Art. No. SAP: 560.0001.411

Torsion spring

Pos. CSS: 560.0001.412
 Art. No. SAP: 560.0001.412

Drive frame assembled with latch

Pos. CSS: 560.0544.055
 Art. No. SAP: 560.0544.055

O-ring Ø38x5 FKM

Pos. CSS: 560.0564.131
 Art. No. SAP: 560.0564.131

Brew. piston Ø50E orifice 0.6 assembled

Pos. CSS: 560.0564.276
 Art. No. SAP: 560.0564.276

Brewing piston assembly Ø50E orifice 0.6

Pos. CSS: 560.0564.278
 Art. No. SAP: 560.0564.278

Support brewing unit

Pos. CSS: 560.0580.811
 Art. No. SAP: 560.0580.811

Center grooved pin Ø3x16 1.4305	
Pos. CSS:	560.0001.417
Art. No. SAP:	560.0001.417
<hr/>	
Brewing module Ø50E w/ orifice 0,6mm	
Pos. CSS:	14824
Art. No. SAP:	560.0001.697
<hr/>	
Spring for lock actuation cooling unit	
Pos. CSS:	560.0002.334
Art. No. SAP:	560.0002.334
<hr/>	
O-ring 4.48x1.78 VMQ	
Pos. CSS:	5779
Art. No. SAP:	560.0005.354
<hr/>	
PT Countersunk screw Phillips KA30x8	
Pos. CSS:	5183
Art. No. SAP:	560.0005.640
<hr/>	
Hexalobular socket pan head screw M4x20	
Pos. CSS:	5067
Art. No. SAP:	560.0005.704
<hr/>	
Blind rivet nut M4 Ø11.1/7.9 11.4	
Pos. CSS:	2254
Art. No. SAP:	560.0005.774
<hr/>	

Mounting bracket BG	
Pos. CSS:	560.0581.227
Art. No. SAP:	560.0581.227
<hr/>	
O-ring 31x5 FKM	
Pos. CSS:	560.0595.044
Art. No. SAP:	560.0595.044
<hr/>	
Brew. piston Ø43E orifice 0.6 assembled	
Pos. CSS:	560.0602.413
Art. No. SAP:	560.0602.413
<hr/>	
Brewing piston assy Ø43E w/ orifice 0,6	
Pos. CSS:	560.0602.950
Art. No. SAP:	560.0602.950
<hr/>	
Brewing module Ø43 with orifice 0.6mm	
Pos. CSS:	560.0637.018
Art. No. SAP:	560.0637.018
<hr/>	
Reed sensor A line	
Pos. CSS:	560.0654.491
Art. No. SAP:	560.0654.491
<hr/>	
Pos. CSS:	
Art. No. SAP:	
<hr/>	

A300 ELEKTRİK ve ELEKTRONİK AKSAM

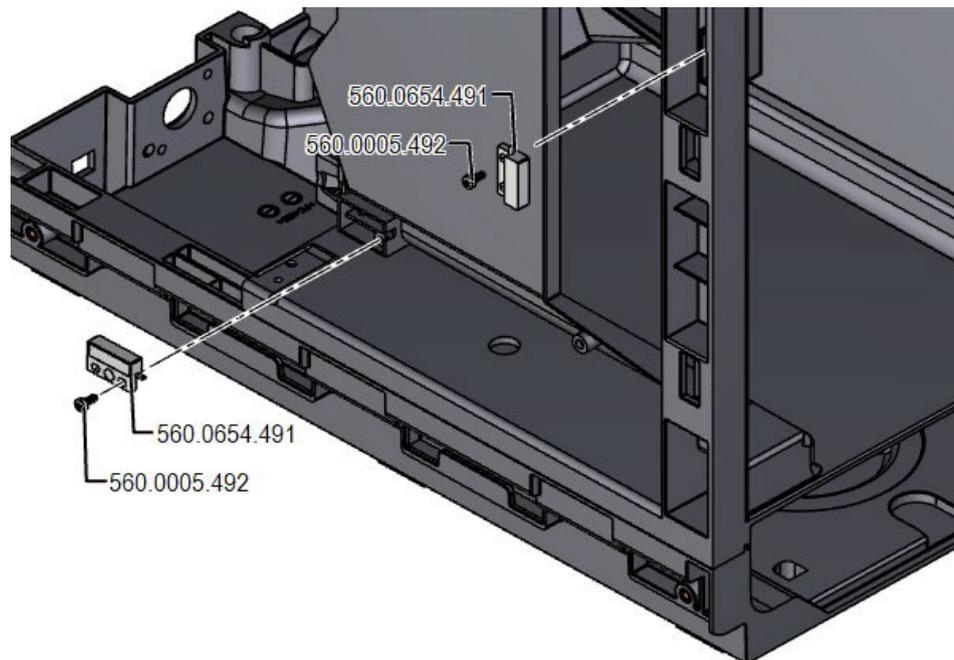
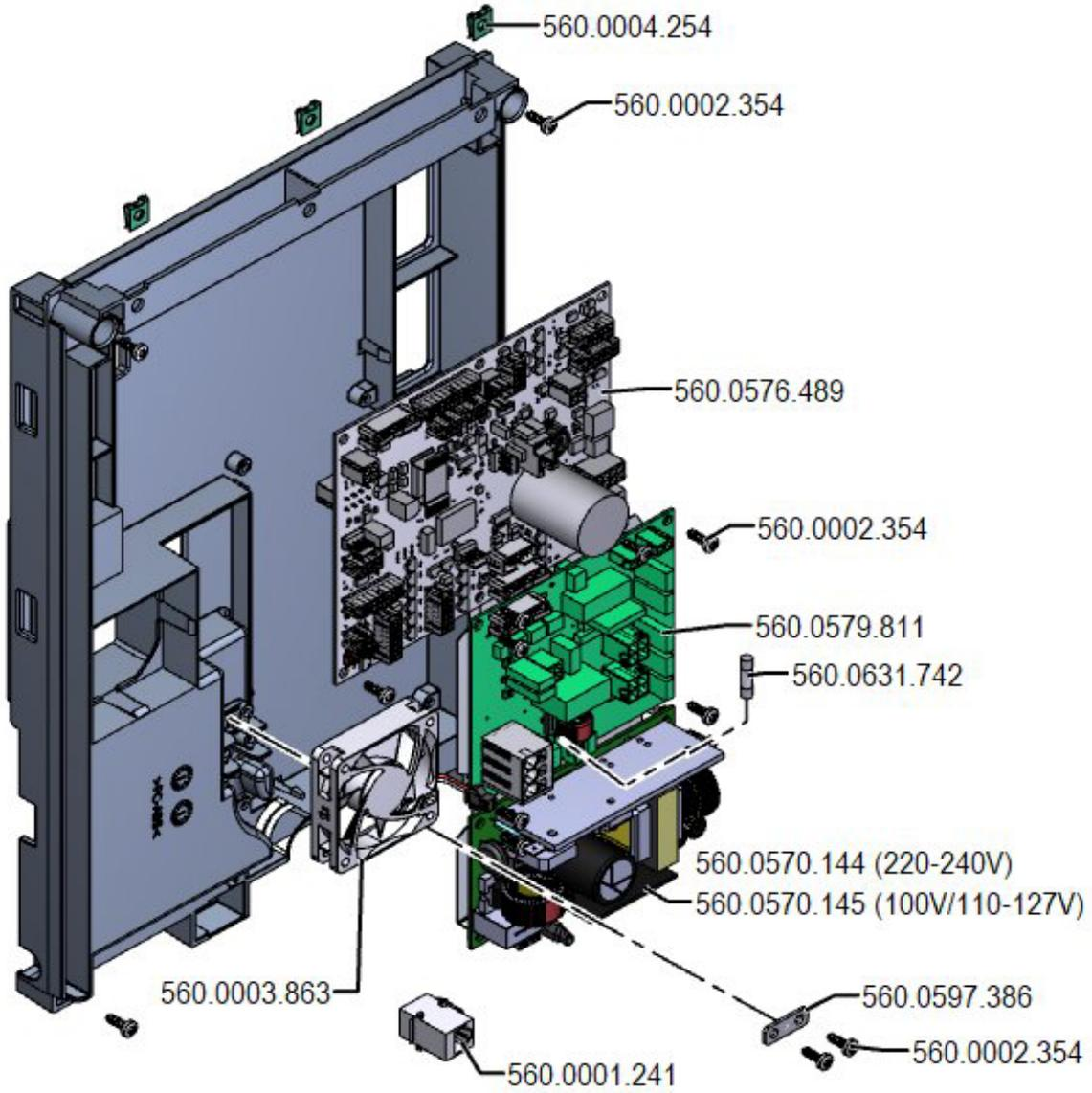

RJ45 socket	
Pos. CSS:	14220
Art. No. SAP:	560.0001.241
Pan head PT screw, K40x12	
Pos. CSS:	6216
Art. No. SAP:	560.0002.354
Fan	
Pos. CSS:	8335
Art. No. SAP:	560.0003.863
Speed nut 2.9 galvanized, yellow chrom.	
Pos. CSS:	39
Art. No. SAP:	560.0004.254
Pan head PT screw, K30x7	
Pos. CSS:	5805
Art. No. SAP:	560.0005.492
Switched-mode power supply TP170A 230V	
Pos. CSS:	560.0570.144
Art. No. SAP:	560.0570.144

Switched-mode power supply TP170B 115V	
Pos. CSS:	560.0570.145
Art. No. SAP:	560.0570.145
Process PCA V7xx	
Pos. CSS:	560.0576.489
Art. No. SAP:	560.0576.489
PCA LIO FCS4070	
Pos. CSS:	560.0579.811
Art. No. SAP:	560.0579.811
Cable strain relief	
Pos. CSS:	560.0597.386
Art. No. SAP:	560.0597.386
Fuse slow blow 5x20 250VAC 16A	
Pos. CSS:	560.0631.742
Art. No. SAP:	560.0631.742
Reed sensor A line	
Pos. CSS:	560.0654.491
Art. No. SAP:	560.0654.491

A300 ISITMA SİSTEMİ (MS)

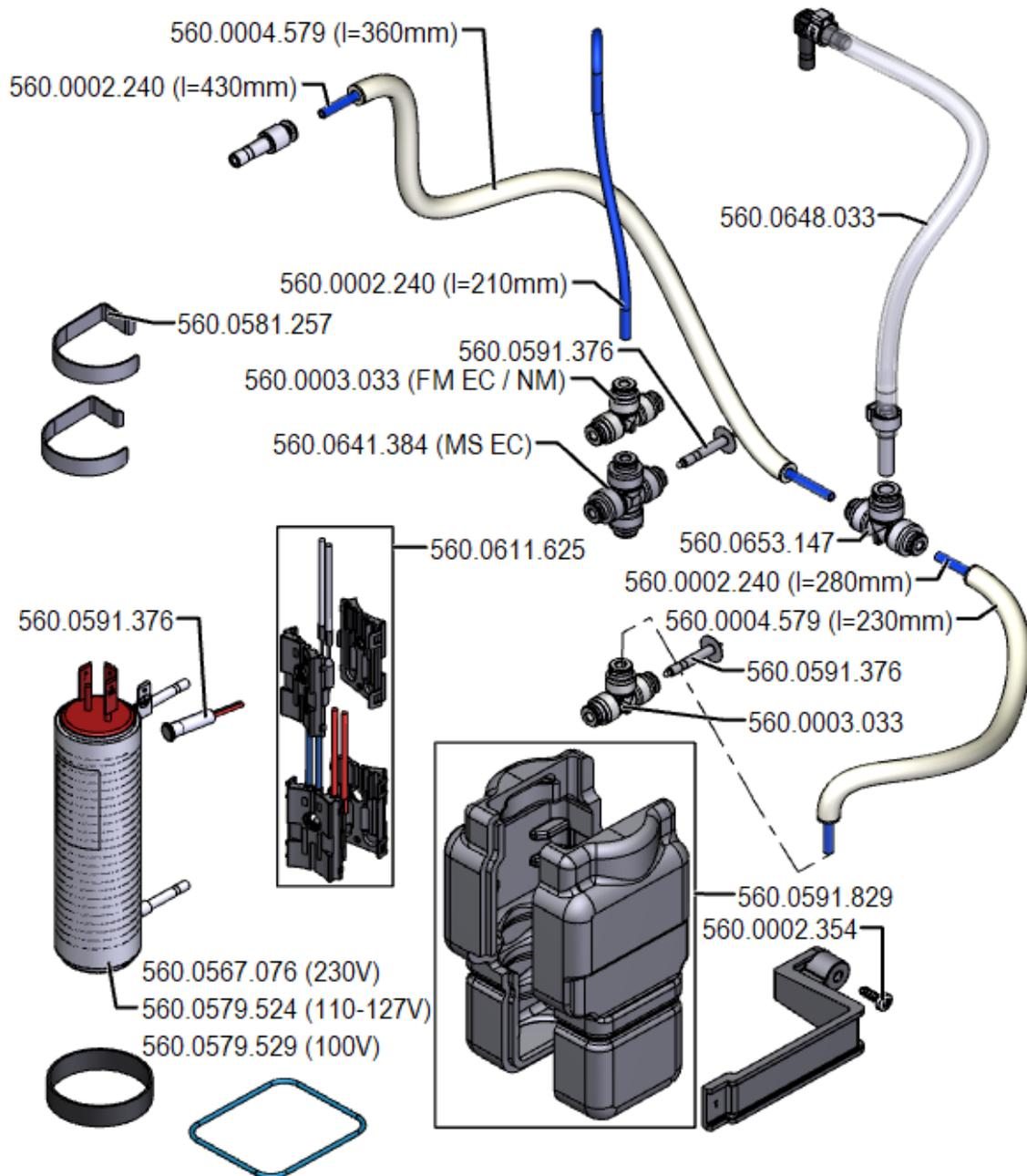

Temperatursensor NTC
 Temperature sensor NTC
 Capteur de température NTC

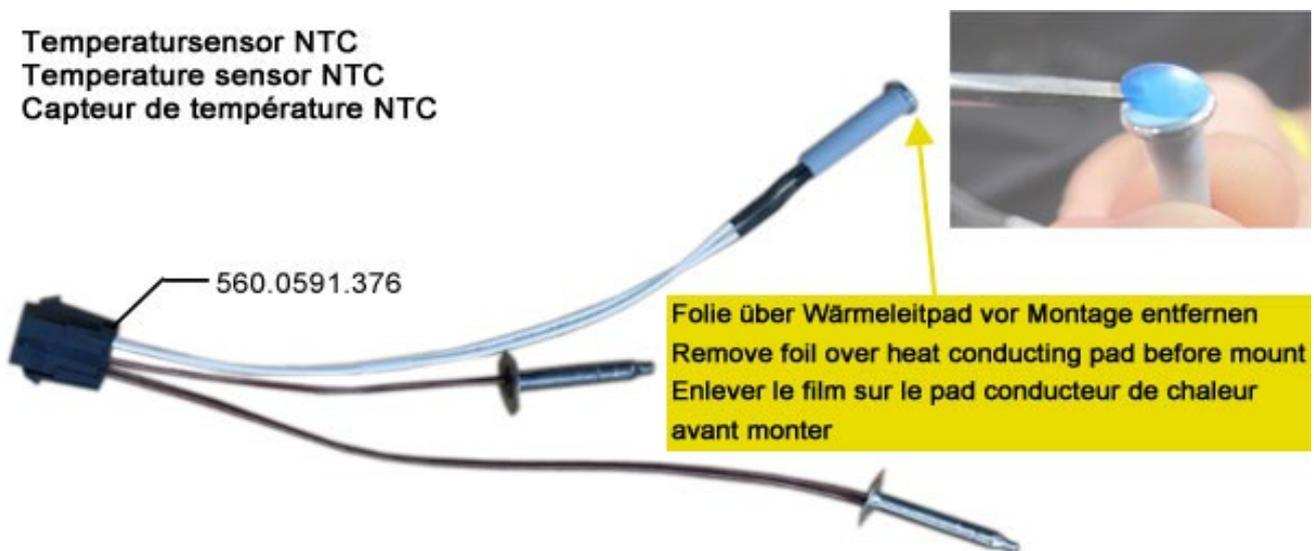

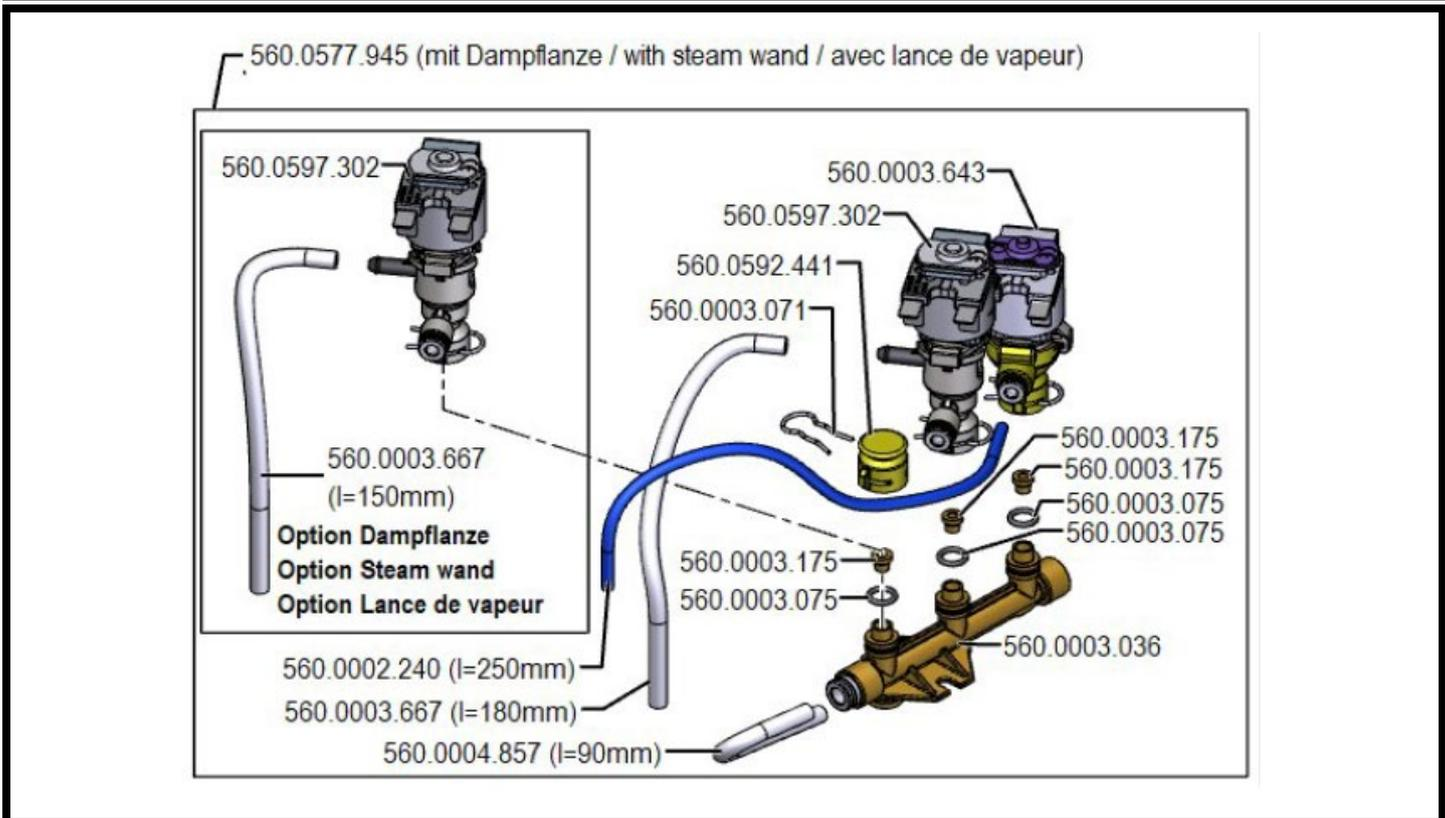
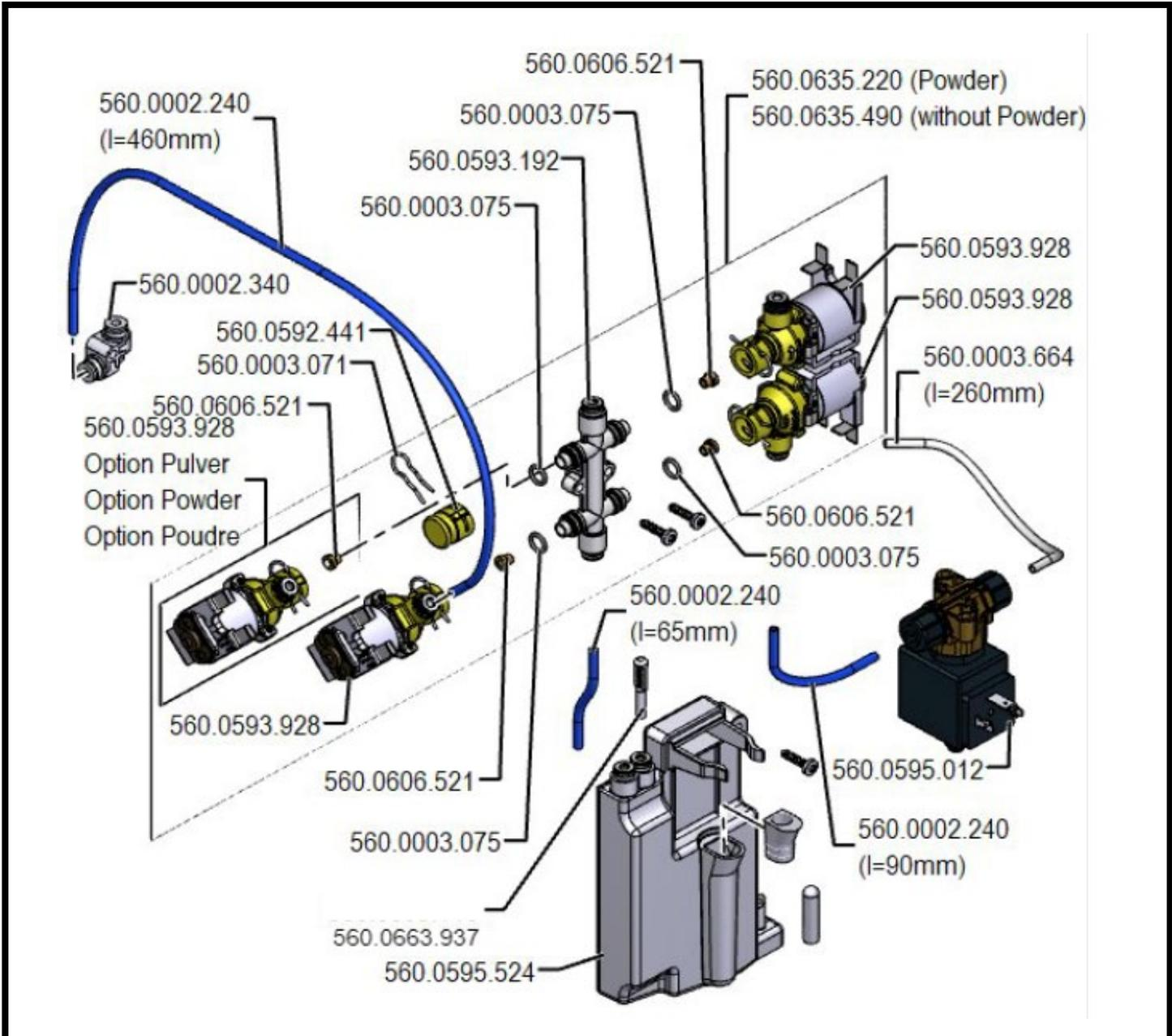

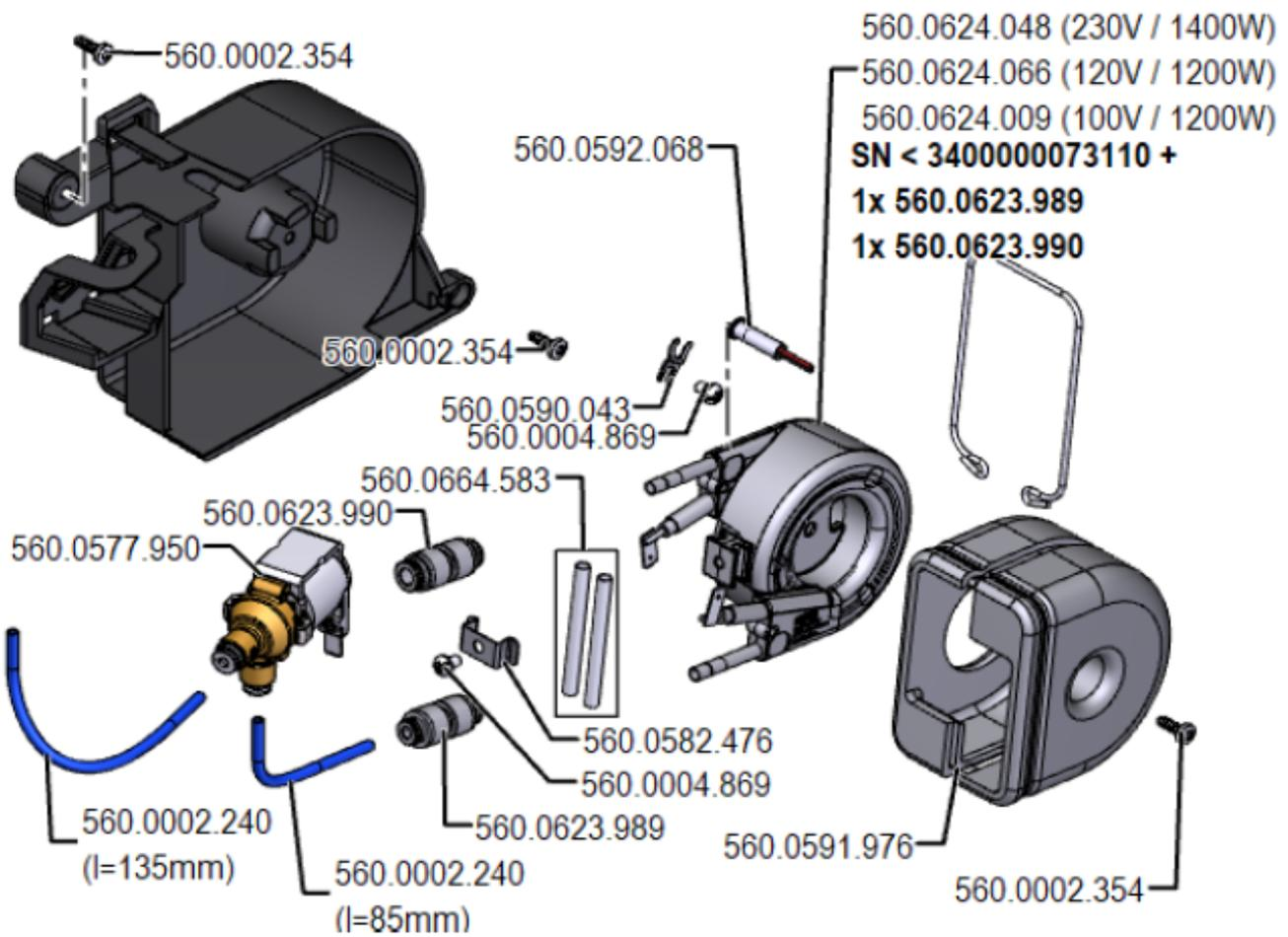

Kabel X106
X106 Cable X106
 Câble X106

(184°C / FM EC) 560.0571.208
 (216°C / MS EC) 560.0664.583

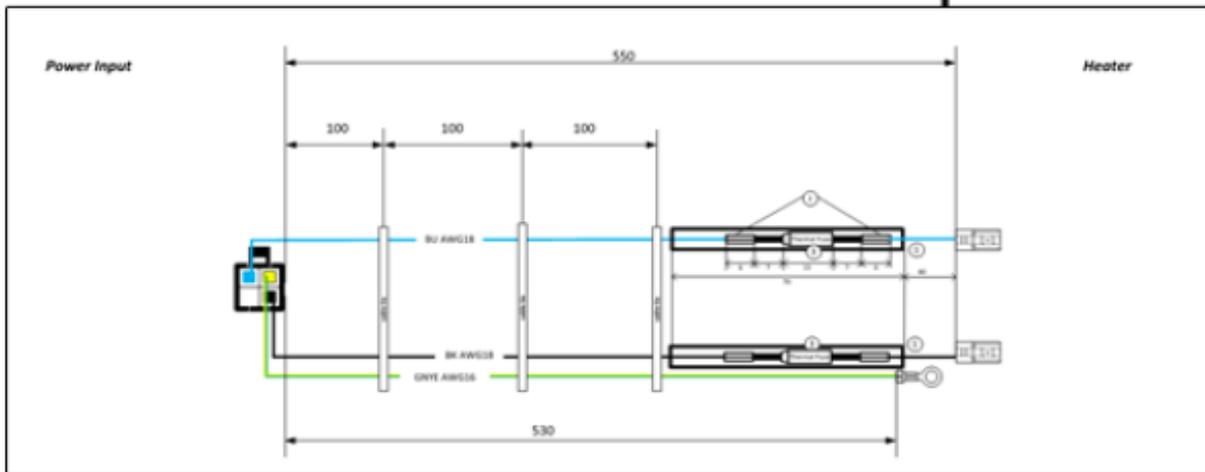

Hose Ø4/2,5 FEP

Pos. CSS: 165
 Art. No. SAP: 560.0002.240

Push-on elbow fitting Ø4/4 PVDF

Pos. CSS: 6962
 Art. No. SAP: 560.0002.340

Pan head PT screw, K40x12

Pos. CSS: 6216
 Art. No. SAP: 560.0002.354

Insulation assembled heating element

Pos. CSS: 560.0591.829
 Art. No. SAP: 560.0591.829

MS-TB insulation assembled

Pos. CSS: 560.0591.976
 Art. No. SAP: 560.0591.976

NTC temperature sensor surface

Pos. CSS: 560.0592.068
 Art. No. SAP: 560.0592.068

Push-on Tee fitting Ø4/4/4 PPSU	
Pos. CSS:	7395
Art. No. SAP:	560.0003.033
Manifold 1-3	
Pos. CSS:	7437
Art. No. SAP:	560.0003.036
Spring clip	
Pos. CSS:	7439
Art. No. SAP:	560.0003.071
O-ring 6.7x1.8 silicone	
Pos. CSS:	7438
Art. No. SAP:	560.0003.075
Valve seat Ø3 PPSU	
Pos. CSS:	7466
Art. No. SAP:	560.0003.175
2/2-way control valve PPSU	
Pos. CSS:	7800
Art. No. SAP:	560.0003.643
Hose Ø4/2 PFA	
Pos. CSS:	273
Art. No. SAP:	560.0003.664
Hose Ø6/3 MVQ	
Pos. CSS:	241
Art. No. SAP:	560.0003.667
Hose Ø9/5 MVQ	
Pos. CSS:	3509
Art. No. SAP:	560.0004.579
Hose Ø6/4 PFA	
Pos. CSS:	140
Art. No. SAP:	560.0004.857
Thread-rolling screw M4x6	
Pos. CSS:	104
Art. No. SAP:	560.0004.869
Heating cartridge 2100W @230V	
Pos. CSS:	560.0567.076
Art. No. SAP:	560.0567.076
Triple steam valve assembly	
Pos. CSS:	560.0577.945
Art. No. SAP:	560.0577.945
2/2-way valve 1.5mm	
Pos. CSS:	560.0577.950
Art. No. SAP:	560.0577.950
Heating cartridge 1200W @120V	
Pos. CSS:	560.0579.524
Art. No. SAP:	560.0579.524
Heating cartridge 1200W @100V	
Pos. CSS:	560.0579.529
Art. No. SAP:	560.0579.529

Lid hot water manifold	
Pos. CSS:	560.0592.441
Art. No. SAP:	560.0592.441
Manifold hot water assembled	
Pos. CSS:	560.0593.192
Art. No. SAP:	560.0593.192
Valve 1.5mm pushfit 4mm	
Pos. CSS:	560.0593.928
Art. No. SAP:	560.0593.928
Brewing valve FCS4070	
Pos. CSS:	560.0595.012
Art. No. SAP:	560.0595.012
Drainage box with PFC FCS4070	
Pos. CSS:	560.0595.524
Art. No. SAP:	560.0595.524
3/2-way valve PPSU	
Pos. CSS:	560.0597.302
Art. No. SAP:	560.0597.302
Valve seat Ø2	
Pos. CSS:	560.0606.521
Art. No. SAP:	560.0606.521
Cable X108 assembly	
Pos. CSS:	560.0611.625
Art. No. SAP:	560.0611.625
Straight push-on fitting 958P3-5-4FF-S8	
Pos. CSS:	560.0623.989
Art. No. SAP:	560.0623.989
Straight push-on fitting 958P3-6-5FF-S8	
Pos. CSS:	560.0623.990
Art. No. SAP:	560.0623.990
Thermoblock 1200W @100V assembled	
Pos. CSS:	560.0624.009
Art. No. SAP:	560.0624.009
Thermoblock 1400W @230V assembled	
Pos. CSS:	560.0624.048
Art. No. SAP:	560.0624.048
Thermoblock 1200W @120V assembled	
Pos. CSS:	560.0624.066
Art. No. SAP:	560.0624.066
Quadruple hot water valve group SP	
Pos. CSS:	560.0635.220
Art. No. SAP:	560.0635.220
Triple hot water valve group SP	
Pos. CSS:	560.0635.490
Art. No. SAP:	560.0635.490
Cross-shaped push-on fitting Ø4-4-4-4	
Pos. CSS:	560.0641.384
Art. No. SAP:	560.0641.384

Spring
Pos. CSS: 560.0581.257
Art. No. SAP: 560.0581.257

Spring clip
Pos. CSS: 560.0582.476
Art. No. SAP: 560.0582.476

Sensor spring clip
Pos. CSS: 560.0590.043
Art. No. SAP: 560.0590.043

Temperature sensors NTC, heating cartr.
Pos. CSS: 560.0591.376
Art. No. SAP: 560.0591.376

Hose pump assembled FCS4070
Pos. CSS: 560.0648.033
Art. No. SAP: 560.0648.033

Push-on Tee fitting Ø4/4/6 PPSU
Pos. CSS:
Art. No. SAP: 560.0653.147

Sealing plug Ø4 PPSU
Pos. CSS: 560.0663.937
Art. No. SAP: 560.0663.937

Cable X106 216°C
Pos. CSS:
Art. No. SAP: 560.0664.583

A300 KİREÇ TEMİZLEME SİSTEMİ

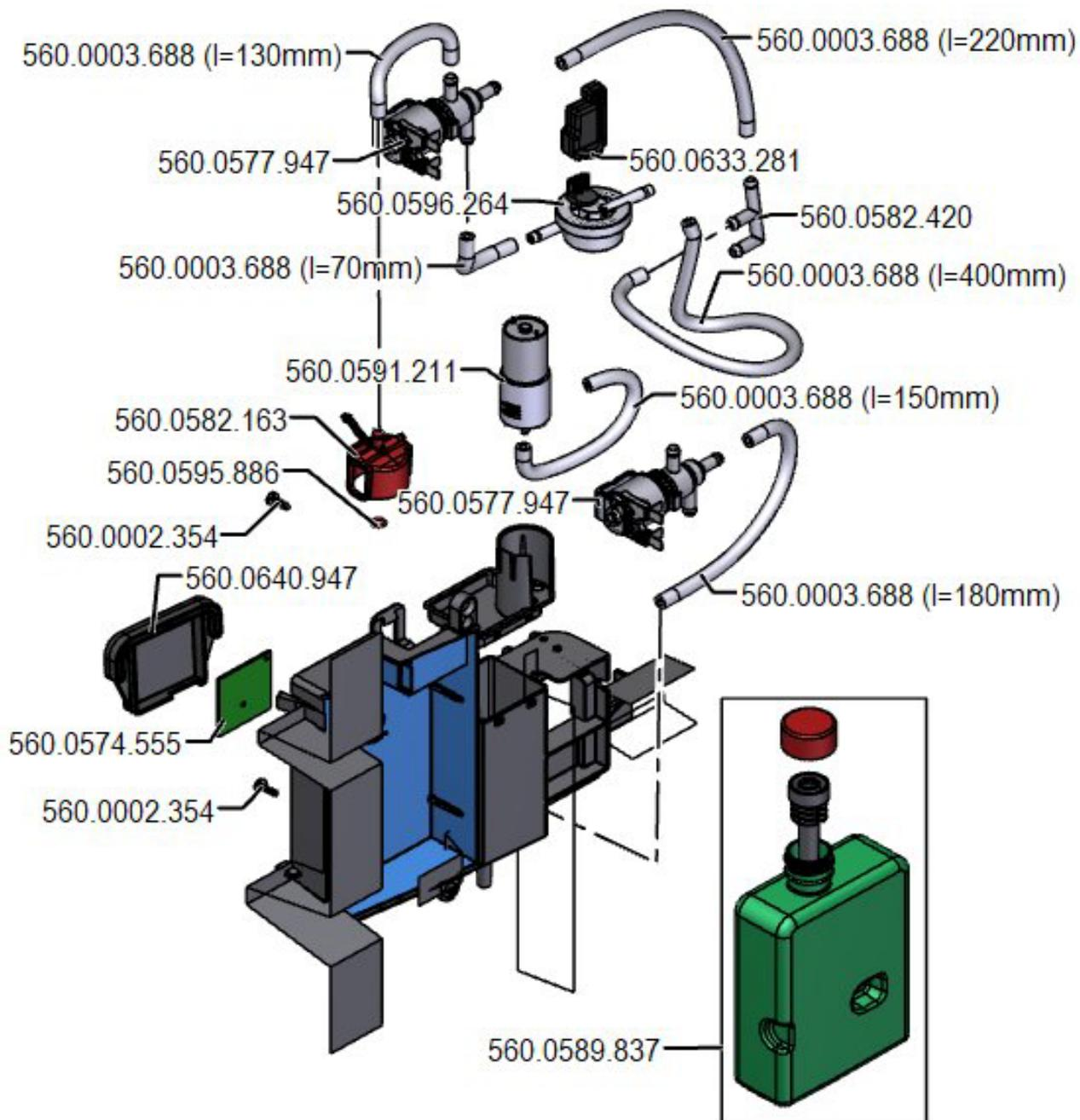

X231 Entkalkungssystem
Descaling system
Système de détartrage

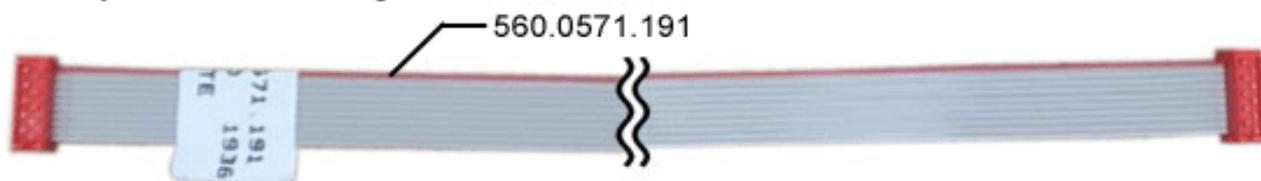

Pan head PT screw, K40x12	
Pos. CSS:	6216
Art. No. SAP:	560.0002.354
<hr/>	
Hose Ø8/4 MVQ	
Pos. CSS:	245
Art. No. SAP:	560.0003.688
<hr/>	
Cable X231 descaling system	
Pos. CSS:	560.0571.191
Art. No. SAP:	560.0571.191
<hr/>	
RFID module	
Pos. CSS:	560.0574.555
Art. No. SAP:	560.0574.555
<hr/>	
3/2-way valve 0.8bar	
Pos. CSS:	560.0577.947
Art. No. SAP:	560.0577.947
<hr/>	
Adapter w/ barbed fittings	
Pos. CSS:	560.0582.163
Art. No. SAP:	560.0582.163
<hr/>	
Barbed F fitting	
Pos. CSS:	560.0582.420
Art. No. SAP:	560.0582.420
<hr/>	

Descaler for coffee machines 0,44l	
Pos. CSS:	560.0589.837
Art. No. SAP:	560.0589.837
<hr/>	
Diaphragm pump	
Pos. CSS:	560.0591.211
Art. No. SAP:	560.0591.211
<hr/>	
O-ring 6x1,5 MVQ	
Pos. CSS:	560.0595.886
Art. No. SAP:	560.0595.886
<hr/>	
Flow meter	
Pos. CSS:	560.0596.264
Art. No. SAP:	560.0596.264
<hr/>	
Splash protection cover	
Pos. CSS:	560.0633.281
Art. No. SAP:	560.0633.281
<hr/>	
Cover RFID module	
Pos. CSS:	560.0640.947
Art. No. SAP:	560.0640.947
<hr/>	
Pos. CSS:	
Art. No. SAP:	
<hr/>	

A300 ÖN KAPAK / OPERATÖR PANELİ (MS)

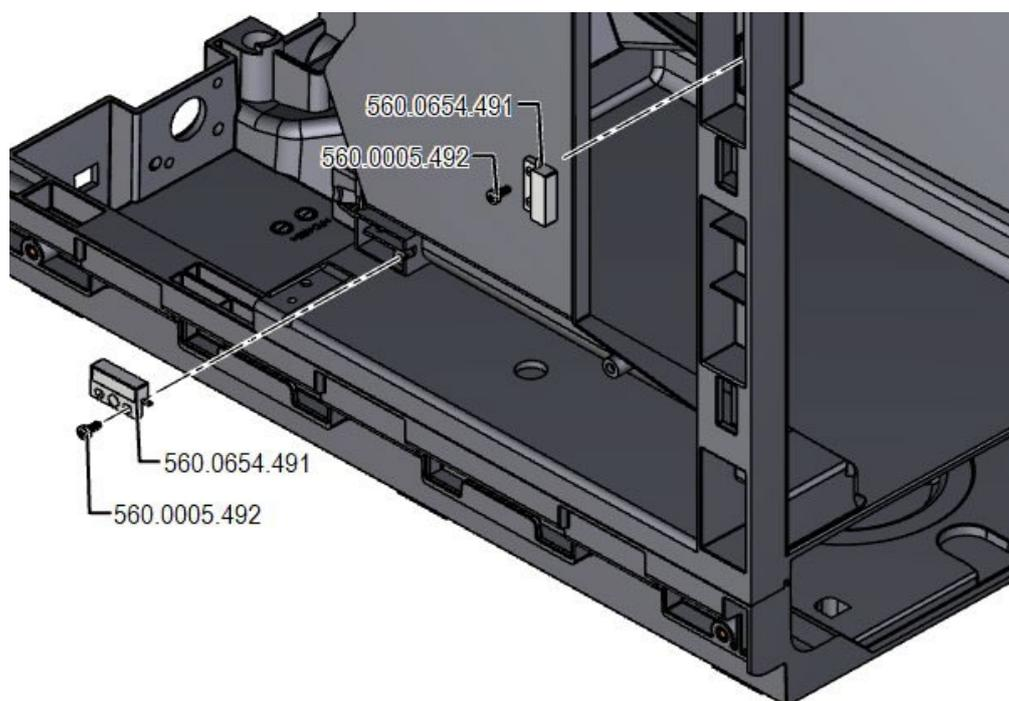
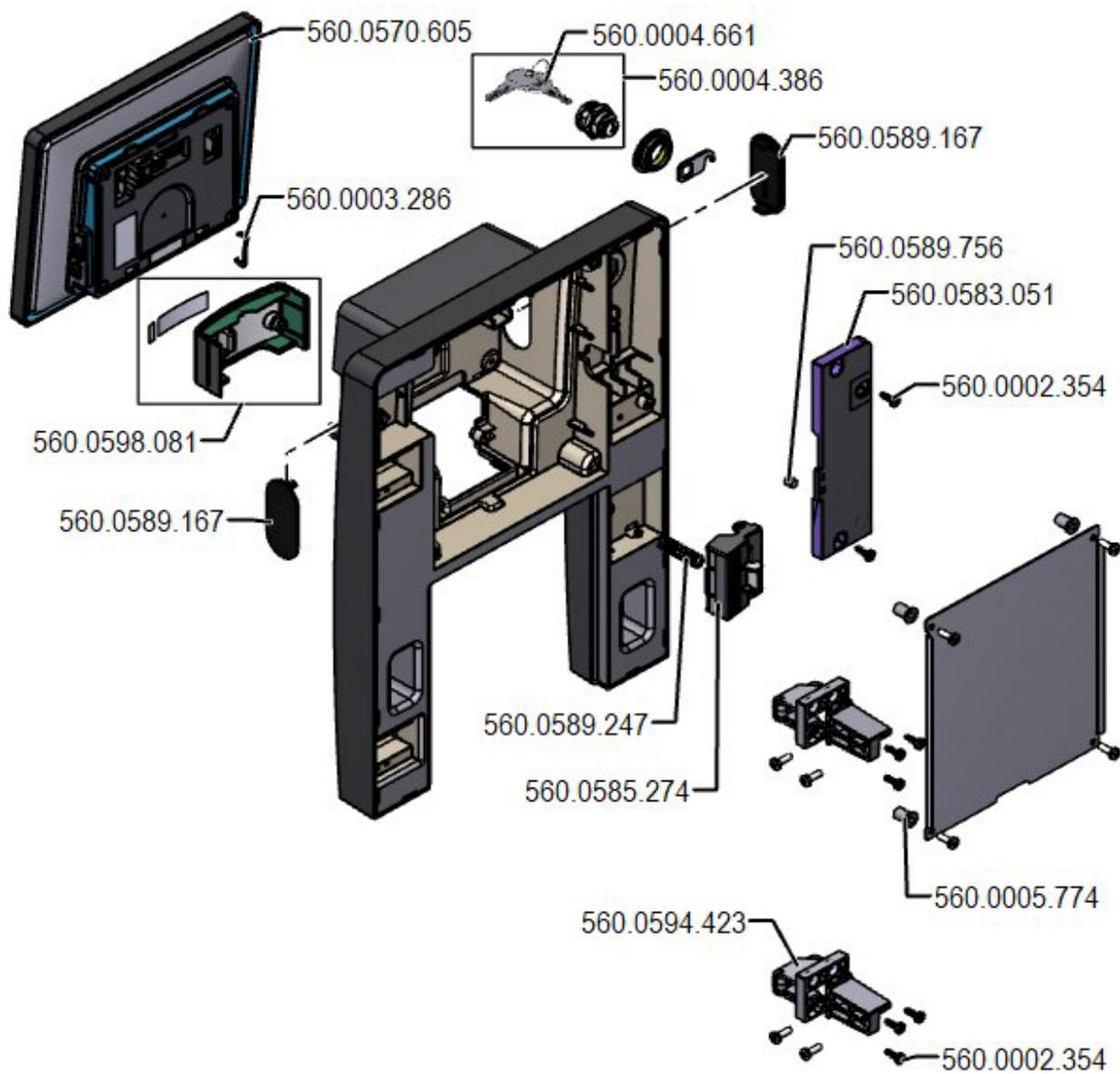

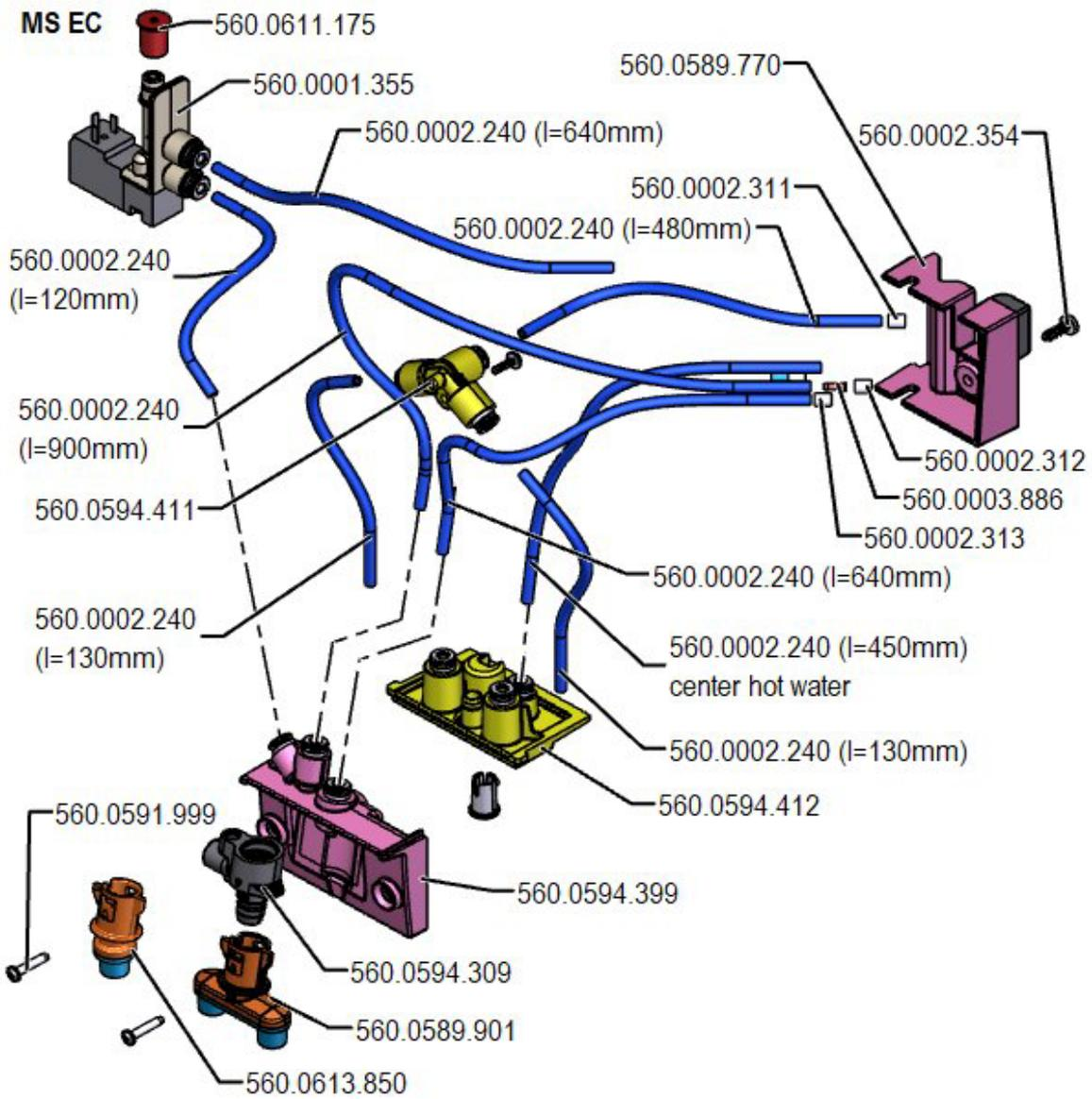

Air valve with valve block PVDF	
Pos. CSS:	14389
Art. No. SAP:	560.0001.355
Hose Ø4/2,5 FEP	
Pos. CSS:	165
Art. No. SAP:	560.0002.240
Marking rings M-37 C	
Pos. CSS:	6791
Art. No. SAP:	560.0002.311
Marking ring M-37 M	
Pos. CSS:	6734
Art. No. SAP:	560.0002.312
Marking ring M-37 S	
Pos. CSS:	6923
Art. No. SAP:	560.0002.313
Pan head PT screw, K40x12	
Pos. CSS:	6216
Art. No. SAP:	560.0002.354

Side cover front holder FCS4070	
Pos. CSS:	560.0589.167
Art. No. SAP:	560.0589.167
Compression spring Ø8,75x33,1 R0,36N	
Pos. CSS:	560.0589.247
Art. No. SAP:	560.0589.247
Round magnet Ø6x6	
Pos. CSS:	560.0589.756
Art. No. SAP:	560.0589.756
Hose/cable guide front door FCS4070	
Pos. CSS:	560.0589.770
Art. No. SAP:	560.0589.770
Milk outlet double FCS4070	
Pos. CSS:	560.0589.901
Art. No. SAP:	560.0589.901
Pan head screw with cross recess K30x16	
Pos. CSS:	560.0591.999
Art. No. SAP:	560.0591.999

Locking bracket	
Pos. CSS:	7581
Art. No. SAP:	560.0003.286
<hr/>	
Orifice Ø2.5x0.8	
Pos. CSS:	8521
Art. No. SAP:	560.0003.886
<hr/>	
Locking cylinder M18x1 ass. with key	
Pos. CSS:	524
Art. No. SAP:	560.0004.386
<hr/>	
Key for lock 1P315206	
Pos. CSS:	2632
Art. No. SAP:	560.0004.661
<hr/>	
Pan head PT screw, K30x7	
Pos. CSS:	5805
Art. No. SAP:	560.0005.492
<hr/>	
Blind rivet nut M4 Ø11.1/7.9 11.4	
Pos. CSS:	2254
Art. No. SAP:	560.0005.774
<hr/>	
Operator panel 8" FCS4070	
Pos. CSS:	560.0570.605
Art. No. SAP:	560.0570.605
<hr/>	
Cover for air regulating valve FCS4070	
Pos. CSS:	560.0583.051
Art. No. SAP:	560.0583.051
<hr/>	
Latch for front door FCS4070	
Pos. CSS:	560.0585.274
Art. No. SAP:	560.0585.274
<hr/>	

Frother head assembly MS EC FCS4070	
Pos. CSS:	560.0594.309
Art. No. SAP:	560.0594.309
<hr/>	
Spout base w/ PFC FCS4070 MS EC	
Pos. CSS:	560.0594.399
Art. No. SAP:	560.0594.399
<hr/>	
Push-on Tee fitting w/ PFC FCS4070	
Pos. CSS:	560.0594.411
Art. No. SAP:	560.0594.411
<hr/>	
Spout base plate w/ PFC FCS4070	
Pos. CSS:	560.0594.412
Art. No. SAP:	560.0594.412
<hr/>	
Hinge FCS4070	
Pos. CSS:	560.0594.423
Art. No. SAP:	560.0594.423
<hr/>	
Spout cover w/ logo FCS4070	
Pos. CSS:	560.0598.081
Art. No. SAP:	560.0598.081
<hr/>	
Orifice Ø0,2	
Pos. CSS:	560.0611.175
Art. No. SAP:	560.0611.175
<hr/>	
Milk outlet single FCS4070	
Pos. CSS:	560.0613.850
Art. No. SAP:	560.0613.850
<hr/>	
reed sensor A line	
Pos. CSS:	560.0654.491
Art. No. SAP:	560.0654.491
<hr/>	

A300 SÜT SİSTEMİ (MS)

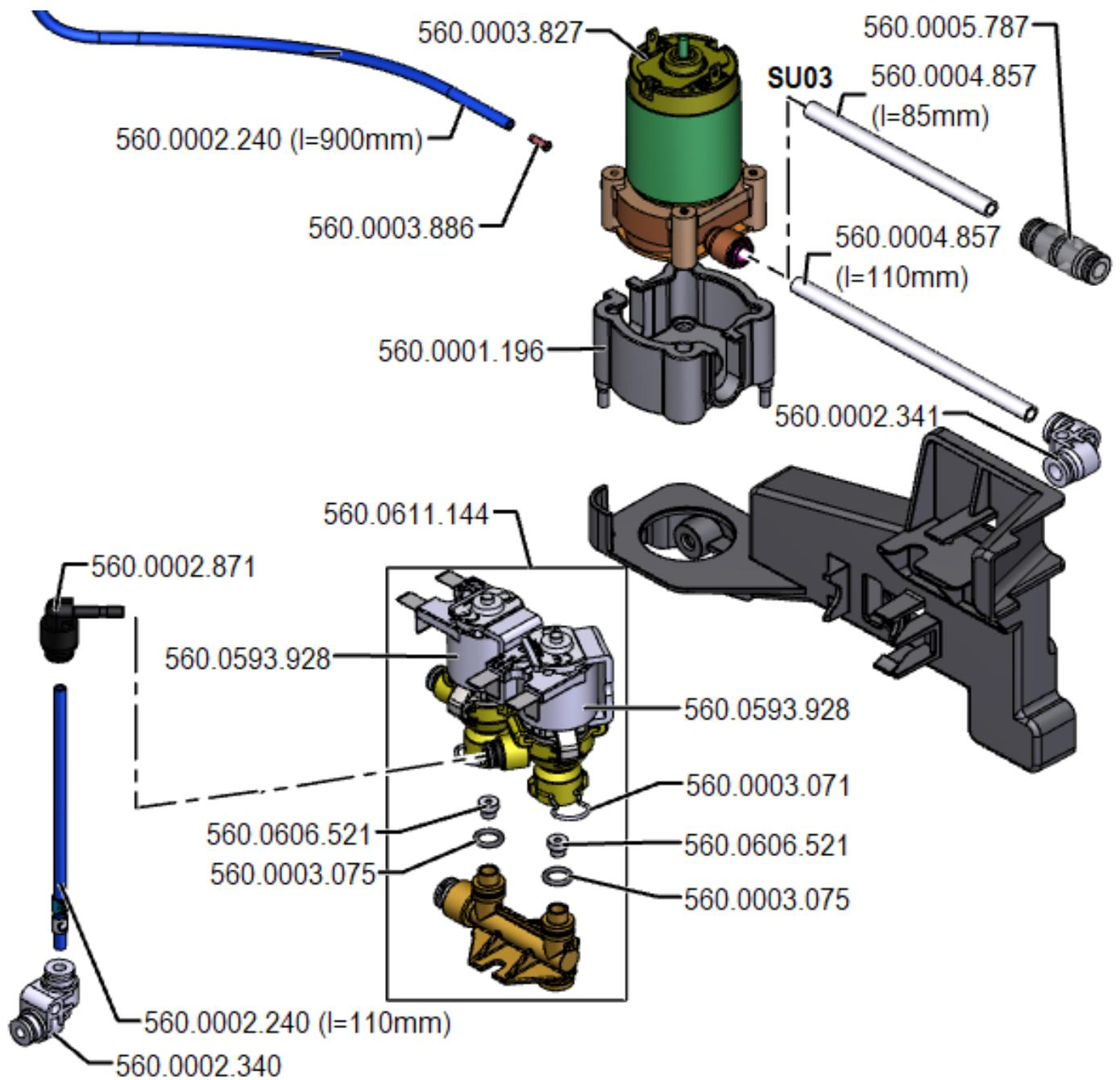

Marking ring M-37 S	
Pos. CSS:	6923
Art. No. SAP:	560.0002.313
<hr/>	
Push-on elbow fitting Ø4/4 PVDF	
Pos. CSS:	6962
Art. No. SAP:	560.0002.340
<hr/>	
Push-on elbow fitting Ø6/6 PVDF	
Pos. CSS:	6345
Art. No. SAP:	560.0002.341
<hr/>	
Pan head PT screw, K40x12	
Pos. CSS:	6216
Art. No. SAP:	560.0002.354
<hr/>	
Push-fit elbow union Ø4/4	
Pos. CSS:	5771
Art. No. SAP:	560.0002.871
<hr/>	
Spring clip	
Pos. CSS:	7439
Art. No. SAP:	560.0003.071
<hr/>	
O-ring 6.7x1.8 silicone	
Pos. CSS:	7438
Art. No. SAP:	560.0003.075
<hr/>	
Gear pump Johnson Electric	
Pos. CSS:	8515
Art. No. SAP:	560.0003.827
<hr/>	
Orifice Ø2.5x0.8	
Pos. CSS:	8521
Art. No. SAP:	560.0003.886
<hr/>	

Valve 1.5mm pushfit 4mm	
Pos. CSS:	560.0593.928
Art. No. SAP:	560.0593.928
<hr/>	
Frother head assembly MS EC FCS4070	
Pos. CSS:	560.0594.309
Art. No. SAP:	560.0594.309
<hr/>	
Spout base w/ PFC FCS4070 MS EC	
Pos. CSS:	560.0594.399
Art. No. SAP:	560.0594.399
<hr/>	
Push-on Tee fitting w/ PFC FCS4070	
Pos. CSS:	560.0594.411
Art. No. SAP:	560.0594.411
<hr/>	
Spout base plate w/ PFC FCS4070	
Pos. CSS:	560.0594.412
Art. No. SAP:	560.0594.412
<hr/>	
Valve seat Ø2	
Pos. CSS:	560.0606.521
Art. No. SAP:	560.0606.521
<hr/>	
Double valve group 1.5mm Ø4	
Pos. CSS:	560.0611.144
Art. No. SAP:	560.0611.144
<hr/>	
Orifice Ø0,2	
Pos. CSS:	560.0611.175
Art. No. SAP:	560.0611.175
<hr/>	
Milk outlet single FCS4070	
Pos. CSS:	560.0613.850
Art. No. SAP:	560.0613.850
<hr/>	